



Mini Series (Cabinet Lock)

120lbs Electromagnetic Lock

Model MEL-120 (Unmonitored Version)



Description

120lbs Mini EM Lock is designed to meet easy installation and secure small enclosures with controlled access. Ideal for most compartments due to its versatility and suitable for securing cupboards, cabinets, drawers & lockers.

Standard Features



No Residual



Low Energy Consumption



Cost Savings

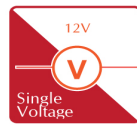

12Vdc only

Extended Features

- Anodized Aluminium Housing
- CE Compliance

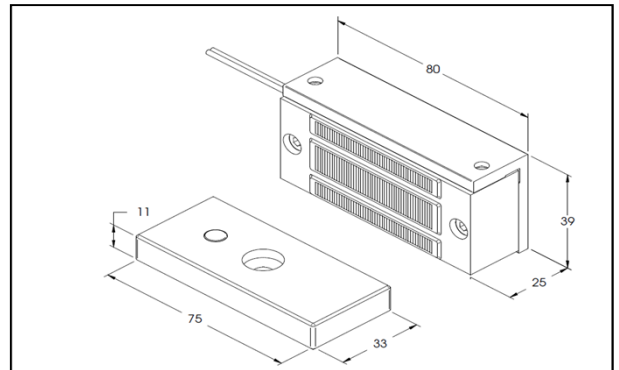

Specification

	MEL-120
Magnet Size	80 X 39 X 25 mm
Armature Size	75 X 33 X 11 mm
Holding Force	Up to 120lbs
Current Drain	130mA±10%/12Vdc
Operating Temperature	(-10 to 66)°C (14 to 131)°F
Est. Weight	0.56kg

WIRING DIAGRAM

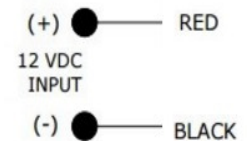

WARRANTY:- EM Lock are warranted against defects in material and workmanship while used in normal service for a period of 1 year from the date of sale to the original customer.

DISCLAIMER:- Specifications are subject to change without prior notice.
- Attached photo is for reference purpose only, actual product may varies.





Mini Series

120lbs Electromagnetic Lock

STANDARD INSTALLATION DIAGRAM

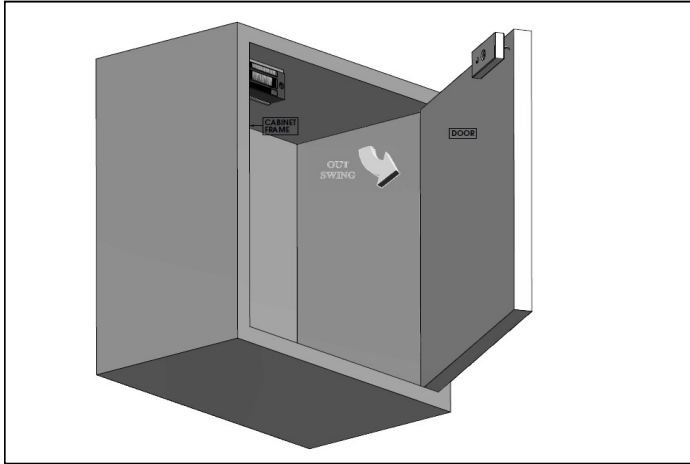

Explode View

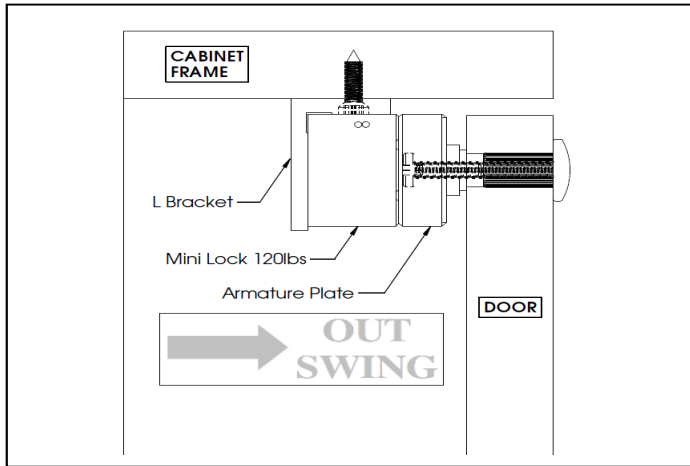

Side View

WARRANTY:- EM Lock are warranted against defects in material and workmanship while used in normal service for a period of 1 year from the date of sale to the original customer.

DISCLAIMER:- Specifications are subject to change without prior notice.

- Attached photo is for reference purpose only, actual product may varies.

